

PASTRY, ICE CREAM & CHOCOLATE

**PASTRY REFRIGERATED COUNTER
 PLUS - 800 - UPSTAND**

Model:

CPCT802ANALXX

Monoblock ventilated refrigeration unit sized for climate class 5 (tropicalization). Easily removable unit for quick and easy maintenance/replacement. Evaporator with cataphoretic coating, automatic defrost managed by digital controller. Condensate water evaporation by means of anti-corrosion coil in low carbon AISI 316. N.2 - doors with automatic closure and fixed opening at 100°. Easily removable, triple chamber magnetic seal. Rounded internal corners for easy and optimal cleaning. AISI 304 stainless steel guides and racks - Adjustable and removable.

TECHNICAL DATA

Temperature (°C)	(0/+10)
Energy class	A
Annual energy consumption AEC (kWh/annum)	416,10
Energy efficiency index EEI	16,95
Daily energy consumption E24 h (kWh)	1,14
Gross volume (L)	388
Net chilling volume (L)	260
Net freezing volume (L)	-
Climate class	5 (+40 °C / 40% R.H.)
Refrigerant gas	R290
GWP	3
Refrigerant charge (kg)	0.090 Kg
Defrosting	AIR
Condensate evaporation	Condensate water evaporation by means of anti-corrosion coil in low carbon AISI 316.
Condensation	AIR
Cooling output (W)	520
Voltage	AC230V 1N+E 50Hz
Special voltages (on request)	Option
Absorbed power (W)	350
Current draw (A)	2,10
Noise (dB)	< 70

CONSTRUCTION DATA

Category	Counter - High performance
Intended use	Storage - This appliance is intended for use in ambient temperatures up to 40 °C.
Internal material	AISI 304 Stainless steel
External material	AISI 304 Stainless Steel (bottom in galvanized steel)
Internal corners	Rounded internal corners for easy and optimal cleaning.
Insulation thickness (mm)	60
Insulation material	HFO Polyurethane (No CFC, no HCFC)
Door seal	Easily removable, triple chamber magnetic seal.
Description of worktop	AISI 304 stainless steel thickness 10/10 with rounded corners at the front and at the base of upstand.
Controller	Capacitive touch screen
Alarm	Visual and audible
NTC temperature probe	Standard
Floor support	Adjustable feet in AISI 304 stainless steel
Floor support height (mm)	Feet: 100-150 Castors: 110 - Ø 80

SEDE OPERATIVA / PLACE OF BUSINESS

 Via Fabio Filzi, 46 - 31036 Istrana (TV) - Italy
 +39 0422 832679 / info@dal-mec.it

SEDE LEGALE / REGISTERED OFFICE

 Dal Santo Srl - Via Sant'Anna, 38 - 31050 Fossalunga di Veduggio (TV) - Italy
 Partita IVA / VAT number 04207260268

CPCT802ANALXX

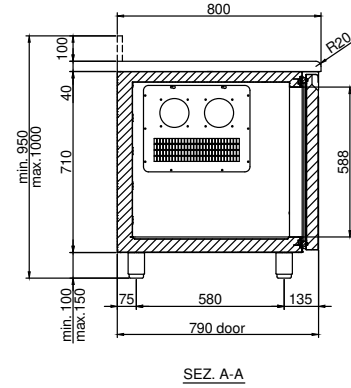
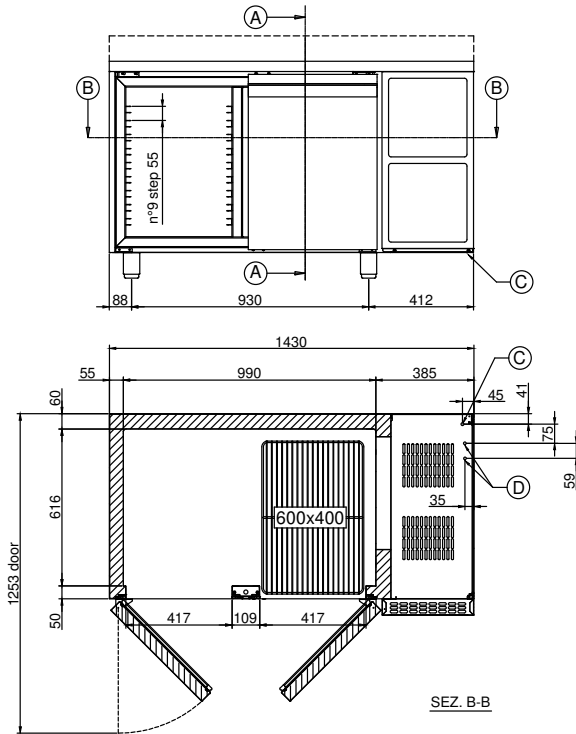

- A. Section plane
- B. Section plane
- C. Power cable outlet (length 2 m)
WARNING! While installing, have a qualified electrician connect it to an electrical panel.
- D. Gas pipes outlet (Ø 6 mm delivery and Ø 10 mm suction)
Ready for remote motor.

Minimum clearances
WARNING! The distance from hot appliances (e.g. fryers or ovens) must be at least 500 mm.

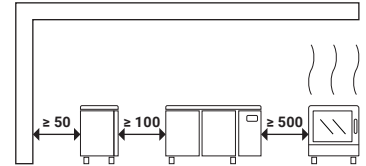

EQUIPMENT AND SETUPS

Internal setup	AISI 304 stainless steel guides and racks - Adjustable and removable.
Trays included	N.1 per door - EN 600x400 - Plastic coated
Maximum load per tray (kg)	30
Pairs of guides included	N.1 "L" per door - EN 600x400
Maximum setup capacity	N.9 (step 55 mm) per door - EN 600x400
Drawers	Option (Interchangeability between doors and drawers)
LED bar	Not available
Wi-Fi kit	Option
Bluetooth kit	Option
Lock with key	Not available
Air distribution duct	Not available
Front removable motor	Option
Openable control panel	Option
Castors kit	Option
Cable with Schuko or English plug	Standard

DIMENSIONS AND WEIGHTS

Dimensions LxDxH (mm)	1430x800x950-1000
Package LxDxH (mm)	1470x830x1100
Net weight (kg)	106
Gross weight (kg)	122