

PASTRY, ICE CREAM & CHOCOLATE

**PASTRY REFRIGERATED COUNTER
 PLUS - 800**

Model:

CPCT802DBXX

Monoblock ventilated refrigeration unit sized for climate class 5 (tropicalization). Easily removed unit for quick and easy maintenance/replacement. Evaporator with cataphoretic coating, automatic defrost managed by digital controller. Condensate water evaporation by means of anti-corrosion coil in low carbon AISI 316. N.2 - doors with automatic closure and fixed opening at 100°. Easily removed, triple chamber magnetic seal. Rounded corners inside for easy and optimal cleaning. AISI 304 stainless steel guides and racks - Adjustable and removable.

TECHNICAL DATA

| | |
|-------------------------------------------|--------------------------------------------------------------------------------------|
| Temperature (°C) | (-22/-18) |
| Energy class | D |
| Annual energy consumption AEC (kWh/annum) | 3473 |
| Energy efficiency index EEI | - |
| Daily energy consumption E24 h (kWh) | - |
| Gross volume (L) | 388 |
| Net chilling volume (L) | - |
| Net freezing volume (L) | 260 |
| Climate class | 5 (+40°C / 40% R.H.) |
| Refrigerant gas | R290 |
| GWP | 3 |
| Refrigerant charge (kg) | 0.100 kg |
| Defrosting | ELECTRIC |
| Condensate evaporation | Condensate water evaporation by means of anti-corrosion coil in low carbon AISI 316. |
| Condensation | AIR |
| Cooling output (W) | 568 |
| Voltage | AC230V 1N+T 50Hz |
| Special voltages (on request) | Optional |
| Absorbed power (W) | 950 |
| Current draw (A) | 4,50 |
| Noise (dB) | < 70 |

CONSTRUCTION DATA

| | |
|---------------------------|----------------------------------------------------------------------------------|
| Category | Counter - High performance |
| Intended use | Storage - This appliance is intended for use in ambient temperatures up to 40°C. |
| Internal material | AISI 304 Stainless Steel |
| External material | AISI 304 Stainless Steel (bottom in galvanized steel) |
| Internal corners | Rounded corners inside for easy and optimal cleaning. |
| Insulation thickness (mm) | 60 |
| Insulation material | HFO Polyurethane (No CFC, no HCFC) |
| Door seal | Easily removed, triple chamber magnetic seal. |
| Worktop | AISI 304 stainless steel thickness 10/10 with rounded front corners. |
| Controller | Capacitive touch screen |
| Alarm | Visual and audible |
| NTC temperature probe | Standard |
| Floor support | Adjustable legs in AISI 304 stainless steel |
| Floor support height (mm) | Legs: 100-150 Castors: 110 - Ø 80 |

SEDE OPERATIVA / PLACE OF BUSINESS

 Via Fabio Filzi, 46 - 31036 Istrana (TV) - Italy
 +39 0422 832679 / info@dal-mec.it

SEDE LEGALE / REGISTERED OFFICE

 Dal Santo Srl - Via Sant'Anna, 38 - 31050 Fossalunga di Veduggio (TV) - Italy
 Partita IVA / VAT number 04207260268

CPCT802DBXX

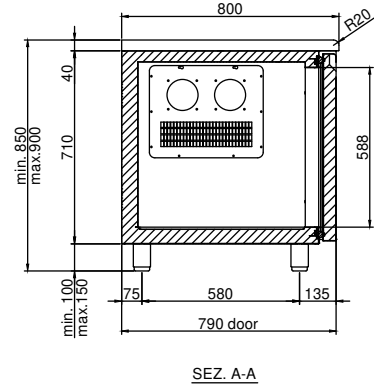
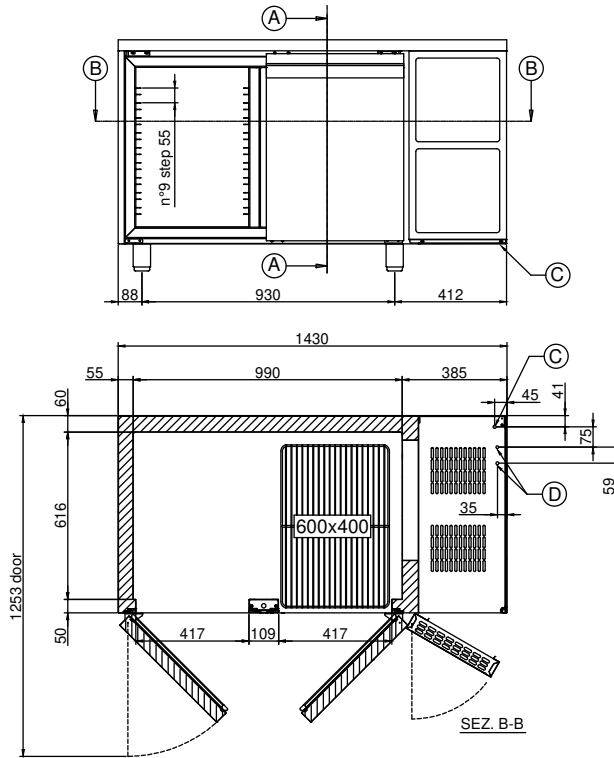

- A. Viewing plane
- B. Viewing plane
- C. Power cable outlet (length 2 m)
WARNING! While installing, have a qualified electrician connect it to an electrical panel.
- D. Gas pipes outlet (Ø 6 mm delivery and Ø 10 mm suction)
Prepared for remote motor.

Minimum clearances
WARNING! The distance from hot appliances (e.g. fryers or ovens) must be at least 500 mm.



EQUIPMENT AND FITTINGS

| | |
|-----------------------------------|-----------------------------------------------------------------------|
| Internal fittings | AISI 304 stainless steel guides and racks - Adjustable and removable. |
| Trays included | N.1 per door - EN 600x400 - Plastic coated |
| Maximum load per tray (kg) | 20 |
| Pairs of guides included | N.1 "L" per door - EN 600x400 |
| Maximum setup capacity | N.9 (step 55 mm) per door - EN 600x400 |
| Drawers | Optional (Interchangeability between doors and drawers) |
| LED bar | Not available |
| Wi-Fi kit | Optional |
| Bluetooth kit | Optional |
| Lock with key | Not available |
| Air distribution duct | Not available |
| Front removable motor | Optional |
| Openable control panel | Optional |
| Castors kit | Optional |
| Cable with Schuko or English plug | Standard |

DIMENSIONS AND WEIGHTS

| | |
|-----------------------|------------------|
| Dimensions LxDxH (mm) | 1430x800x850-900 |
| Package LxDxH (mm) | 1470x830x1100 |
| Net weight (kg) | 107 |
| Gross weight (kg) | 123 |

SEDE OPERATIVA / PLACE OF BUSINESS

Via Fabio Filzi, 46 - 31036 Istrana (TV) - Italy
+39 0422 832679 / info@dal-mec.it

SEDE LEGALE / REGISTERED OFFICE

Dal Santo Srl - Via Sant'Anna, 38 - 31050 Fossalunga di Vedelago (TV) - Italy
Partita IVA / VAT number 04207260268

