

CATERING

 REFRIGERATED COUNTER
PLUS - 600 - UPSTAND

Model:

PPCT603DBALXX

Monoblock ventilated refrigeration unit sized for climate class 5 (tropicalization). Easily removed unit for quick and easy maintenance/replacement. Evaporator with cataphoretic coating, automatic defrost managed by digital controller. Condensate water evaporation by means of anti-corrosion coil in low carbon AISI 316. N.3 - doors with automatic closure and fixed opening at 100°. Easily removed, triple chamber magnetic seal. Rounded corners inside for easy and optimal cleaning. AISI 304 stainless steel guides and racks - Adjustable and removable.

TECHNICAL DATA

Temperature (°C)	(-22/-18)
Energy class	D
Annual energy consumption AEC (kWh/annum)	2038
Energy efficiency index EEI	-
Daily energy consumption E24 h (kWh)	-
Gross volume (L)	354
Net chilling volume (L)	-
Net freezing volume (L)	227
Climate class	5 (+40°C / 40% R.H.)
Refrigerant gas	R290
GWP	3
Refrigerant charge (kg)	0.100 kg
Defrosting	ELECTRIC
Condensate evaporation	Condensate water evaporation by means of anti-corrosion coil in low carbon AISI 316.
Condensation	AIR
Cooling output (W)	568
Voltage	AC230V 1N+T 50Hz
Special voltages (on request)	Optional
Absorbed power (W)	950
Current draw (A)	4,50
Noise (dB)	< 70

CONSTRUCTION DATA

Category	Counter - High performance
Intended use	Storage - This appliance is intended for use in ambient temperatures up to 40°C.
Internal material	AISI 304 Stainless Steel
External material	AISI 304 Stainless Steel (bottom in galvanized steel)
Internal corners	Rounded corners inside for easy and optimal cleaning.
Insulation thickness (mm)	60
Insulation material	HFO Polyurethane (No CFC, no HCFC)
Door seal	Easily removed, triple chamber magnetic seal.
Worktop	AISI 304 stainless steel thickness 10/10 with rounded corners at front and at base of upstand.
Controller	Capacitive touch screen
Alarm	Visual and audible
NTC temperature probe	Standard
Floor support	Adjustable legs in AISI 304 stainless steel
Floor support height (mm)	Legs: 100-150 Castors: 110 - Ø 80

SEDE OPERATIVA / PLACE OF BUSINESS

 Via Fabio Filzi, 46 - 31036 Istrana (TV) - Italy
 +39 0422 832679 / info@dal-mec.it

SEDE LEGALE / REGISTERED OFFICE

 Dal Santo Srl - Via Sant'Anna, 38 - 31050 Fossalunga di Veduggio (TV) - Italy
 Partita IVA / VAT number 04207260268

PPCT603DBALXX

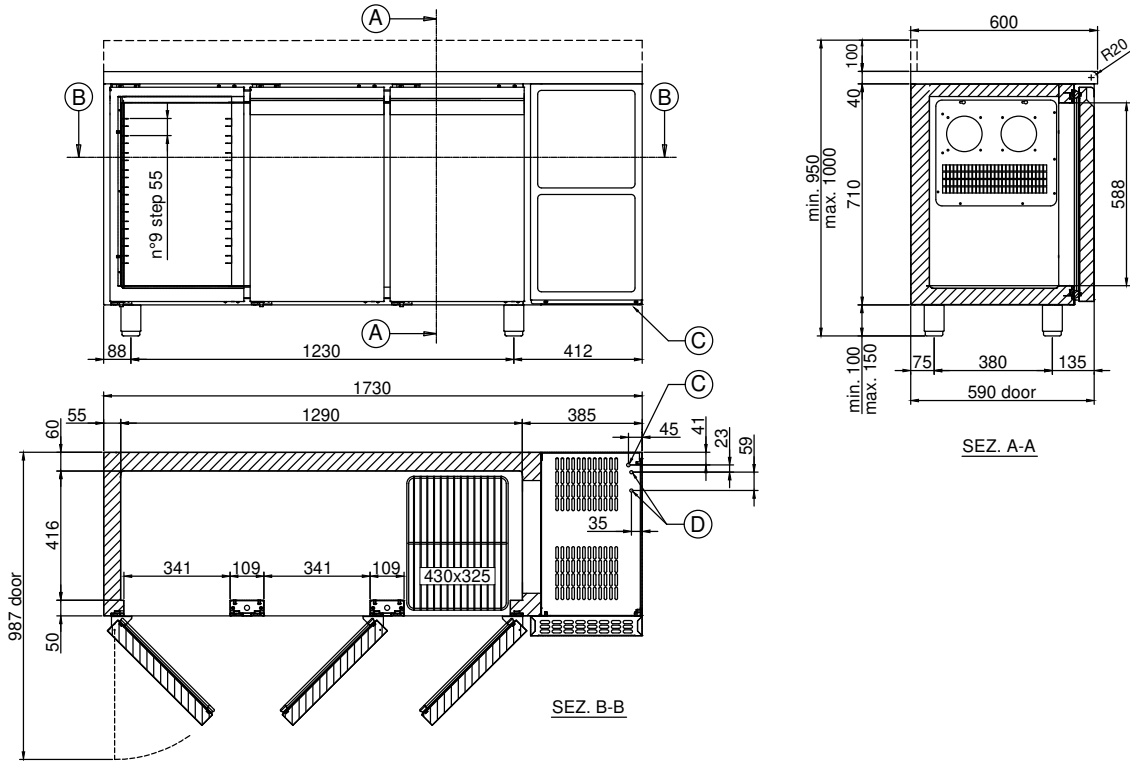

- A. Viewing plane
- B. Viewing plane
- C. Power cable outlet (length 2 m)
WARNING! While installing, have a qualified electrician connect it to an electrical panel.
- D. Gas pipes outlet (Ø 6 mm delivery and Ø 10 mm suction)
Prepared for remote motor.

Minimum clearances
WARNING! The distance from hot appliances (e.g. fryers or ovens) must be at least 500 mm.

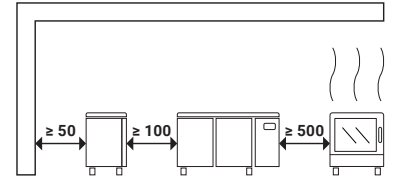

EQUIPMENT AND FITTINGS

Internal fittings	AISI 304 stainless steel guides and racks - Adjustable and removable.
Trays included	N.1 per door - 430x325 - Plastic coated
Maximum load per tray (kg)	-
Pairs of guides included	N.1 "C" per door - 430x325
Maximum setup capacity	N.9 (step 55 mm) per door - 430x325
Drawers	Optional (Interchangeability between doors and drawers)
LED bar	Not available
Wi-Fi kit	Optional
Bluetooth kit	Optional
Lock with key	Not available
Air distribution duct	Not available
Front removable motor	Not available
Openable control panel	Optional
Castors kit	Optional
Cable with Schuko or English plug	Standard

DIMENSIONS AND WEIGHTS

Dimensions LxDxH (mm)	1730x600x950-1000
Package LxDxH (mm)	1770x630x1100
Net weight (kg)	111
Gross weight (kg)	126

SEDE OPERATIVA / PLACE OF BUSINESS

Via Fabio Filzi, 46 - 31036 Istrana (TV) - Italy
+39 0422 832679 / info@dal-mec.it

SEDE LEGALE / REGISTERED OFFICE

Dal Santo Srl - Via Sant'Anna, 38 - 31050 Fossalunga di Vedelago (TV) - Italy
Partita IVA / VAT number 04207260268

PPCT603DBALXX

