

**CATERING**

 REFRIGERATED COUNTER  
**PLUS - 660 - NO WORKTOP**

Model:

**PPCT7B3ANSPXX**

Monoblock ventilated refrigeration unit sized for climate class 5 (tropicalization). Easily removed unit for quick and easy maintenance/replacement. Evaporator with cataphoretic coating, automatic defrost managed by digital controller. Condensate water evaporation by means of anti-corrosion coil in low carbon AISI 316. N.3 - doors with automatic closure and fixed opening at 100°. Easily removed, triple chamber magnetic seal. Rounded corners inside for easy and optimal cleaning. AISI 304 stainless steel guides and racks - Adjustable and removable.

**TECHNICAL DATA**

Temperature (°C)	(0/+10)
Energy class	A
Annual energy consumption AEC (kWh/annum)	-
Energy efficiency index EEI	-
Daily energy consumption E24 h (kWh)	-
Gross volume (L)	393
Net chilling volume (L)	267
Net freezing volume (L)	-
Climate class	5 (+40°C / 40% R.H.)
Refrigerant gas	R290
GWP	3
Refrigerant charge (kg)	0.090 kg
Defrosting	AIR
Condensate evaporation	Condensate water evaporation by means of anti-corrosion coil in low carbon AISI 316.
Condensation	AIR
Cooling output (W)	520
Voltage	AC230V 1N+T 50Hz
Special voltages (on request)	Optional
Absorbed power (W)	350
Current draw (A)	2,10
Noise (dB)	< 70

**CONSTRUCTION DATA**

Category	Counter - High performance
Intended use	Storage - This appliance is intended for use in ambient temperatures up to 40°C.
Internal material	AISI 304 Stainless Steel
External material	AISI 304 Stainless Steel (bottom in galvanized steel)
Internal corners	Rounded corners inside for easy and optimal cleaning.
Insulation thickness (mm)	60
Insulation material	HFO Polyurethane (No CFC, no HCFC)
Door seal	Easily removed, triple chamber magnetic seal.
Worktop	No worktop.
Controller	Capacitive touch screen
Alarm	Visual and audible
NTC temperature probe	Standard
Floor support	Adjustable legs in AISI 304 stainless steel
Floor support height (mm)	Legs: 100-150 Castors: 110 - Ø 80

**SEDE OPERATIVA / PLACE OF BUSINESS**

 Via Fabio Filzi, 46 - 31036 Istrana (TV) - Italy  
 +39 0422 832679 / info@dal-mec.it

**SEDE LEGALE / REGISTERED OFFICE**

 Dal Santo Srl - Via Sant'Anna, 38 - 31050 Fossalunga di Veduggio (TV) - Italy  
 Partita IVA / VAT number 04207260268

**PPCT7B3ANSPXX**

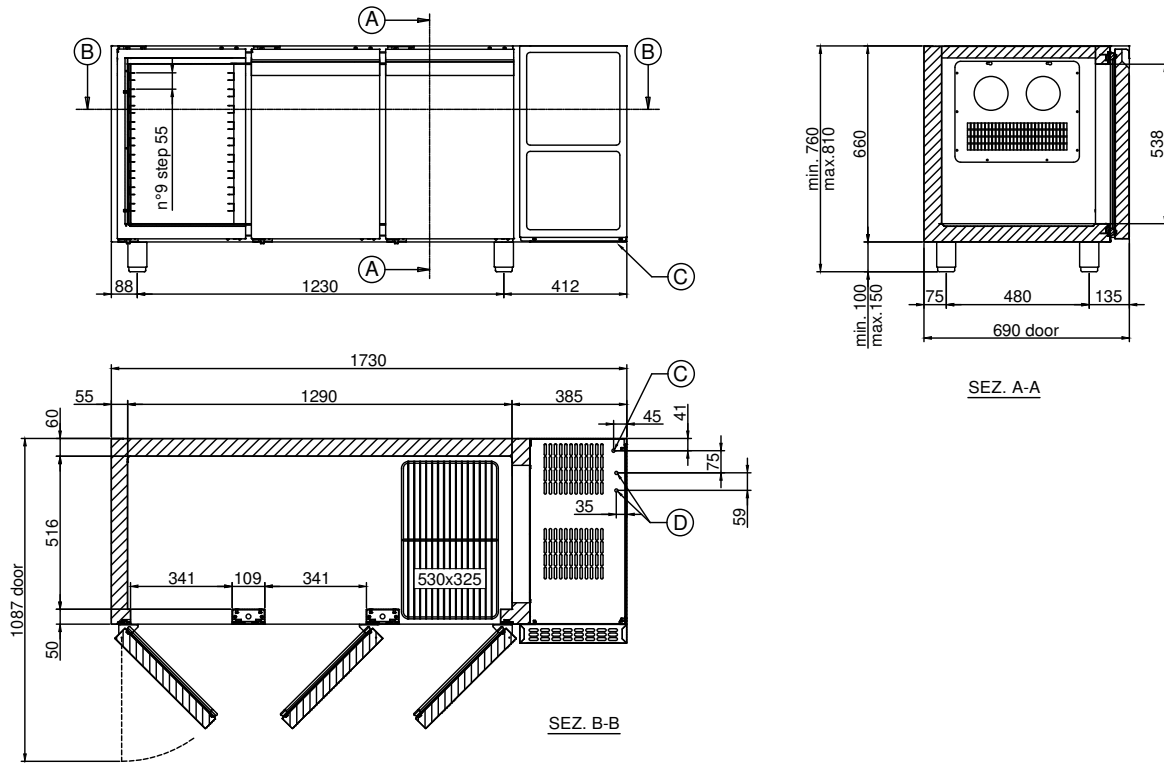

- A. Viewing plane**
- B. Viewing plane**
- C. Power cable outlet (length 2 m)**  
**WARNING! While installing, have a qualified electrician connect it to an electrical panel.**
- D. Gas pipes outlet (Ø 6 mm delivery and Ø 10 mm suction)**  
**Prepared for remote motor.**

**Minimum clearances**  
**WARNING! The distance from hot appliances (e.g. fryers or ovens) must be at least 500 mm.**



## EQUIPMENT AND FITTINGS

<b>Internal fittings</b>	AISI 304 stainless steel guides and racks - Adjustable and removable.
<b>Trays included</b>	N.1 per door - GN 1/1 530x325 - Plastic coated
<b>Maximum load per tray (kg)</b>	20
<b>Pairs of guides included</b>	N.1 "C" per door - GN 1/1 530x325
<b>Maximum setup capacity</b>	N.9 (step 55 mm) per door - GN 1/1 530x325
<b>Drawers</b>	Optional (Interchangeability between doors and drawers)
<b>LED bar</b>	Not available
<b>Wi-Fi kit</b>	Optional
<b>Bluetooth kit</b>	Optional
<b>Lock with key</b>	Not available
<b>Air distribution duct</b>	Not available
<b>Front removable motor</b>	Not available
<b>Openable control panel</b>	Not available
<b>Castors kit</b>	Optional
<b>Cable with Schuko or English plug</b>	Standard

## DIMENSIONS AND WEIGHTS

<b>Dimensions LxDxH (mm)</b>	1730x700x760-810
<b>Package LxDxH (mm)</b>	1770x730x1100
<b>Net weight (kg)</b>	96
<b>Gross weight (kg)</b>	112