

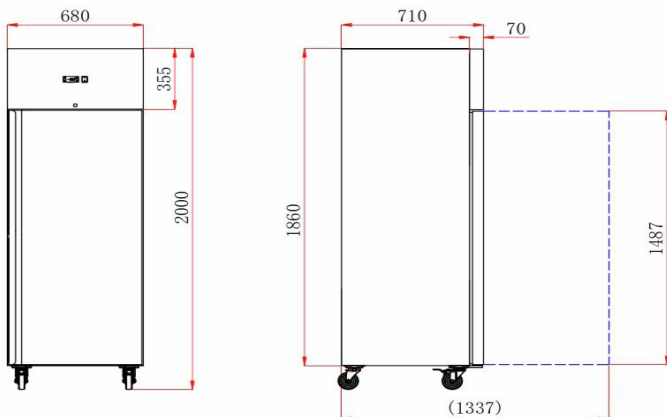

CONSTRUCTION FEATURES

- Stainless cabinet
- Fan cooled interior
- Adjustable shelves
- Digital Controller
- Auto defrost
- Castors standard
- Eco friendly gas
- Self closing door
- Interior light
- High quality compressor
- 3 Shelves included
- Lockable door
- Insulation 60 mm

MEASUREMENTS



TECHNICAL SPECIFICATION

Model	HSR 460 Refrigerator
Dimensions	W 680 x D710 x H2000
Capacity	429 Litres
Shelves	3
Temperature	0°C to +5°C
Compressor	CUBIGEL
Refrigerant	R290
Energy Class	D
Power	13 Amp Plug-in
Nett Weight	115 Kg.

REFRIGERATION SYSTEM

- Refrigeration system uses R290 refrigerant to comply with up to date environmental law
- Automatic defrost without heater
- The system is regulated and programmable by a Dixell electronic controller