

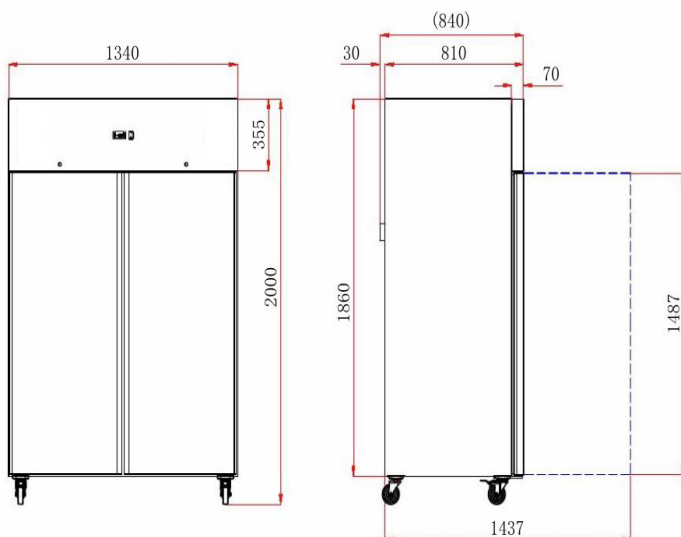

CONSTRUCTION FEATURES

- All stainless cabinet
- Fully ventilated
- Superior technology
- Hygienic interior
- Adjustable shelving
- Full length door handle
- Door lockable
- Digital controller
- Low running costs
- Easy fit door seal
- Castors fitted
- Auto defrost
- Interior light
- Heavy duty build
- High quality compressor
- Insulation 60 mm

MEASUREMENTS



TECHNICAL SPECIFICATION

Model	HVR 1270 Refrigerator
Dimensions	W1340 x D840 x H2000
Gross Capacity	1200 Litres
Shelves	6
Temperature	-2°C to +5°C
Compressor	CUBIGEL
Refrigerant	R290
Energy Class	E
Power	13 Amp Plug-in
Nett Weight	167 Kg.

REFRIGERATION SYSTEM

- Refrigeration system uses R290 refrigerant to comply with up to date environmental law
- Automatic defrost without heater
- The system is regulated and programmable by a Dixell electronic controller